

Teilansicht1

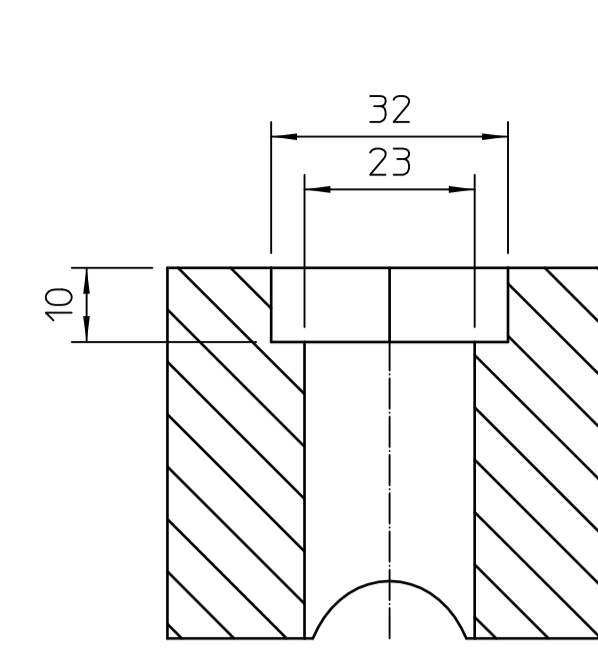

Schnitt A-A  
Maßstab 1:1

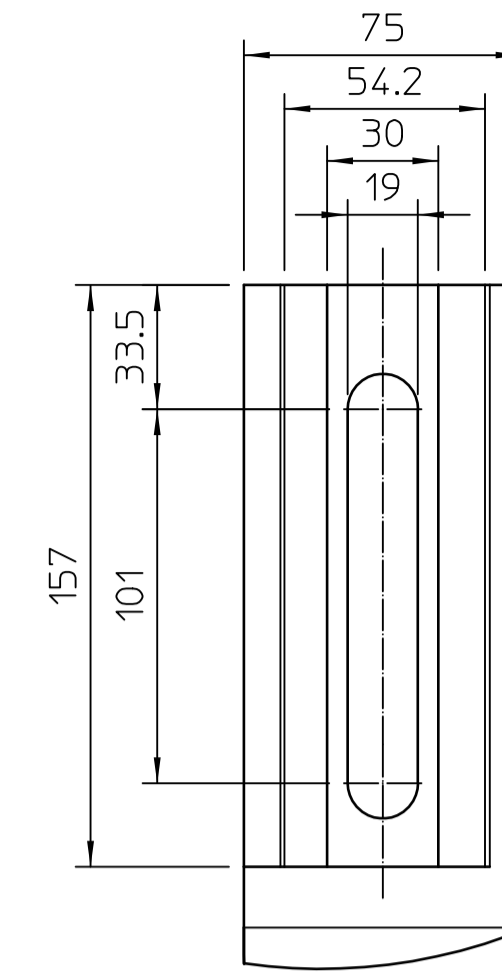

Teilansicht1  
Maßstab 1:2

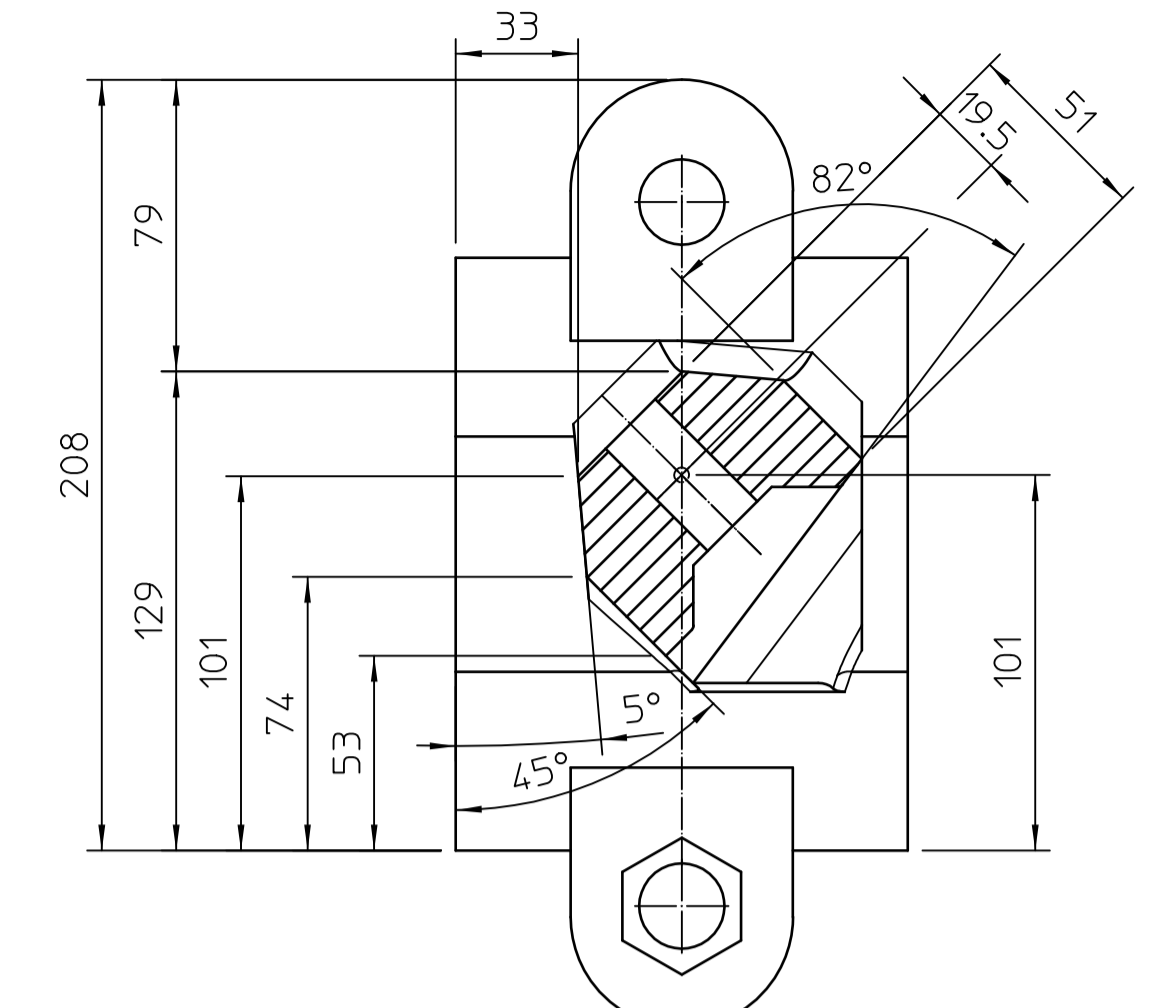

Schnitt C-C

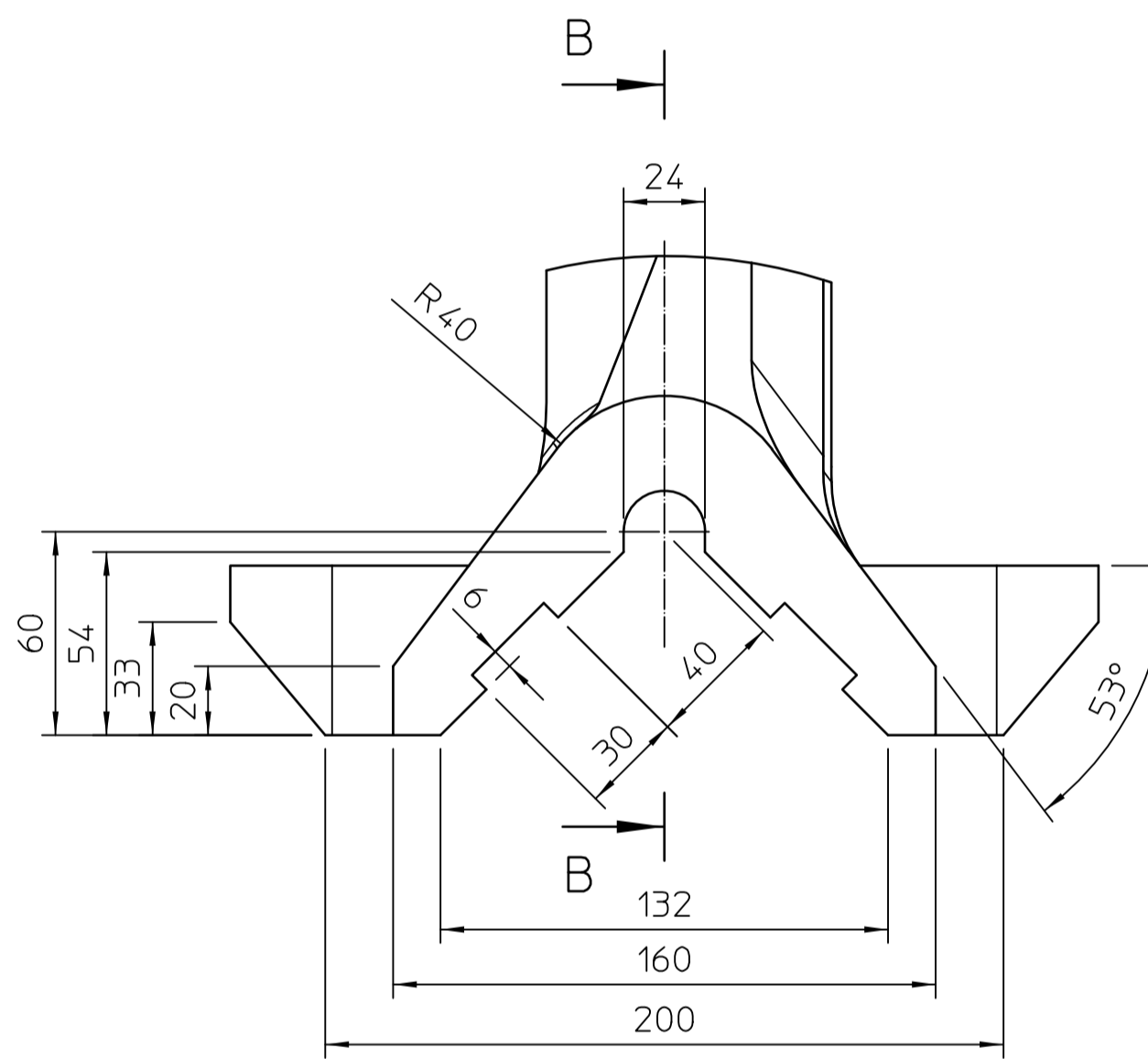

Teilansicht2  
Maßstab 1:2

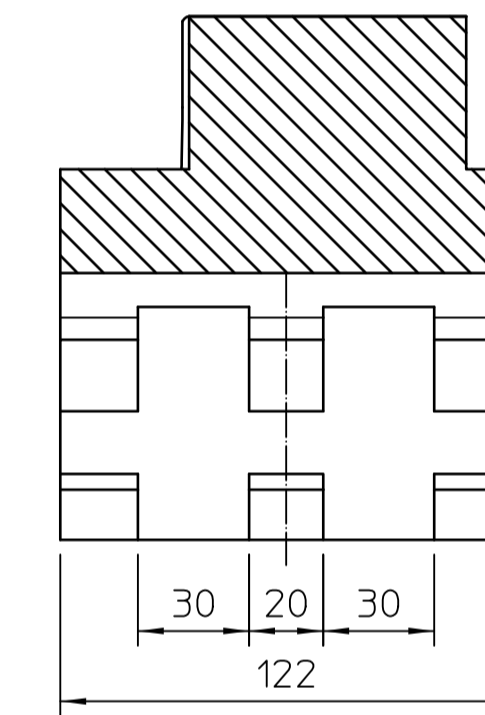

Schnitt B-B

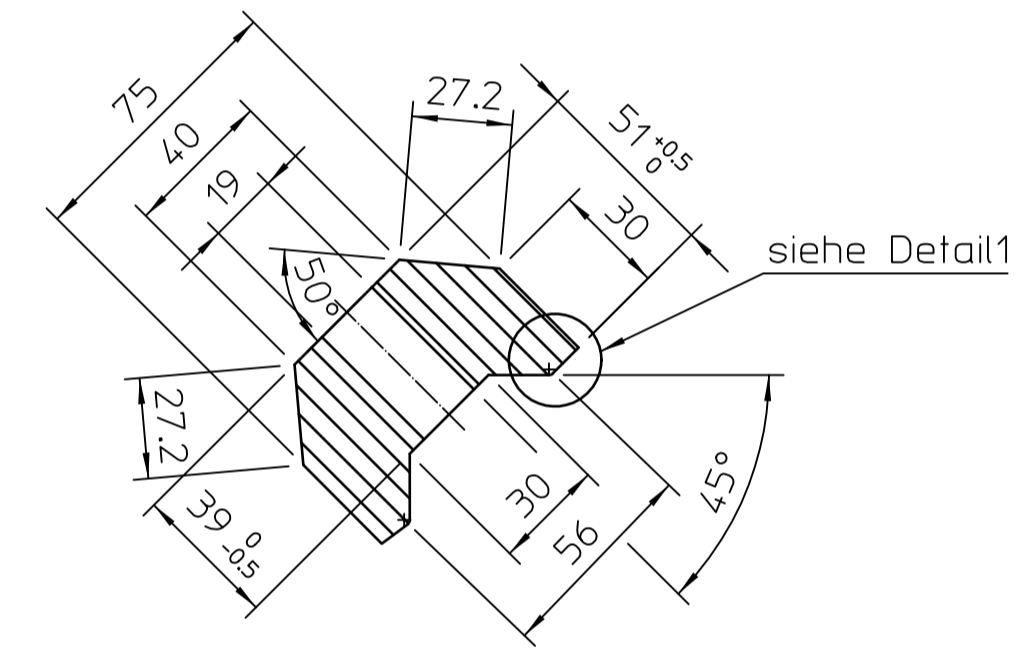

Schnitt D-D

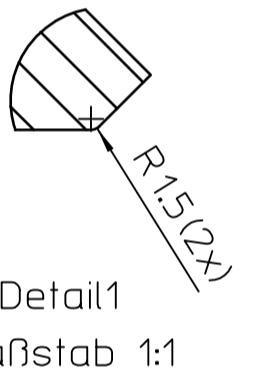

Detail1  
Maßstab 1:1

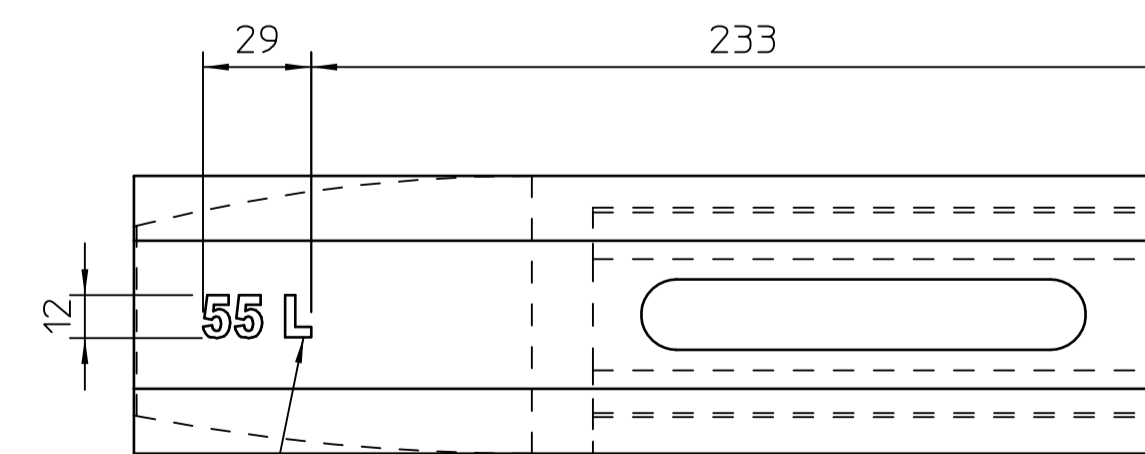

Teilansicht1  
Maßstab 1:2  
1,5 tief  
1,5 深

31.50€/St  
Werkzeug:1200€

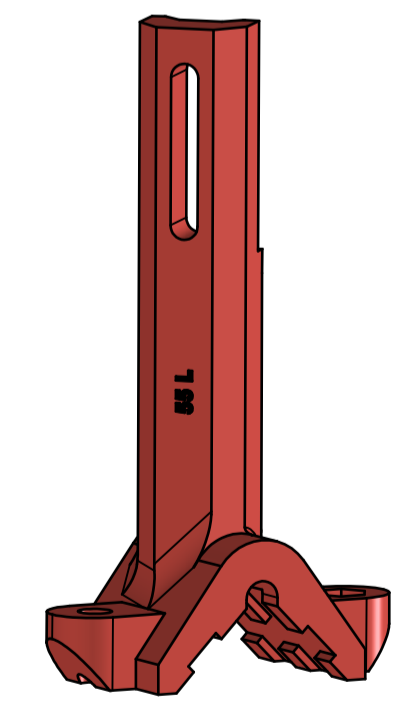

AllgSicht2  
Maßstab 1:5

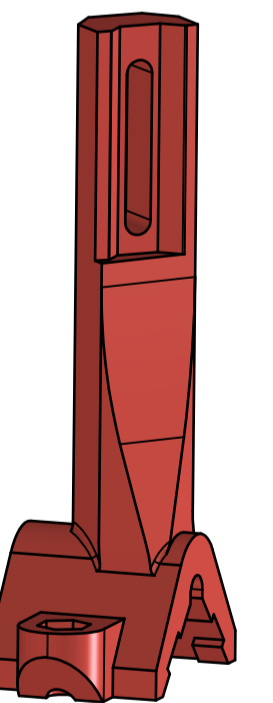

AllgSicht1  
Maßstab 1:5

Posnr	Anzahl	Bezeichnung	Rahmnr	Werkstoff	Gewicht	Artikelnummer	Gusstel
12	1	Winkelarm L M8522x45	75x75x45	spezial Hartguß	17,1		Gusstel
<p>莫克1055项目：铸钢铸件。材料：铸钢，譬如GX120Mn13 (1.3802)或者类似的材料，重量：18.5 kg，每次订货200件</p>							Bezeichnung
							Werkstoff
							Mat.Nr
							Gewicht
							Order Nr.:
							Reg.Nr
							t2
							A1